

# Process connection per EN 837

WIKA data sheet IN 00.03

## Applications

- For the definition of the process connections for WIKA pressure measuring instruments

## Variants

- Process connections with parallel thread
- Process connections with tapered thread
- Industry-specific special connections

## Description

WIKA offers pressure measuring instruments with a variety of process connections in order to meet diverse customer-specific application requirements.

For pressure measuring instruments with parallel or tapered thread, process connections with a range of dimensions are specified.

The permissible maximum pressure of a process connection is a result of the combination of thread size and material. The correlation is illustrated for a selection of representative process connections in a table on page 3.

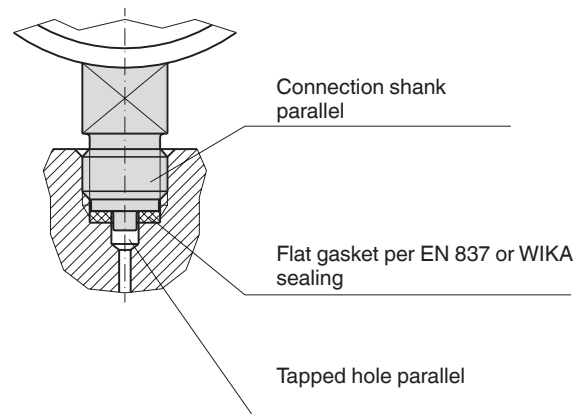

### Installation example with parallel thread

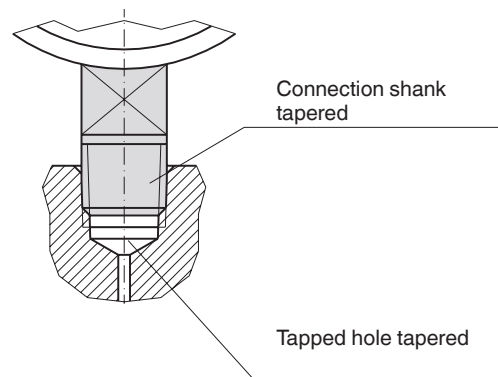

### Installation example with tapered thread

## Connection shank with parallel male thread

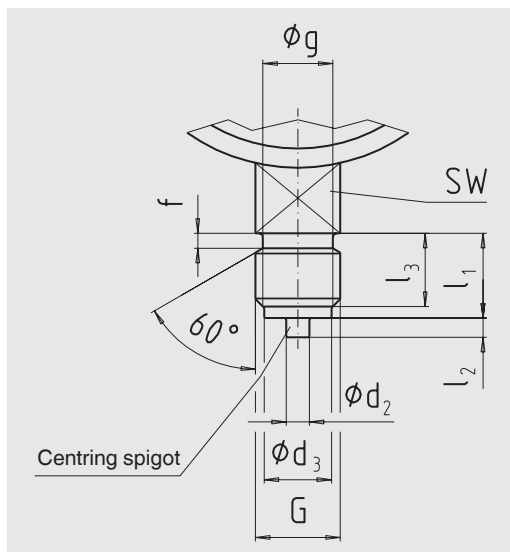

Parallel thread G	Dimensions in mm							
	d2	d3	f with Brass	Stainless steel	g -0.2	$l_1 +0.3$	$l_2 \pm 0.1$	$l_3 +0.3$
G 1/8 1)	2)	8	2)	2)	2)	10	2)	8
M10 x 1	2)	8	2)	2)	2)	10	2)	8
G 1/4 1)	5	9.5	2	3	11	13	2	11
M12 x 1.5	5	9.5	2	3	9.7	13	2	11
G 3/8	5.5	13	2	3	14.5	16	3	13
G 1/2 1)	6	17.5	3	4	18	20	3	17
M20 x 1.5	6	17.5	3	4	17.7	20	3	17

- 1) Preferably with WIKA standard versions  
2) With WIKA, without centring spigot; thread run-out instead of thread undercut

## Connection shank with tapered thread

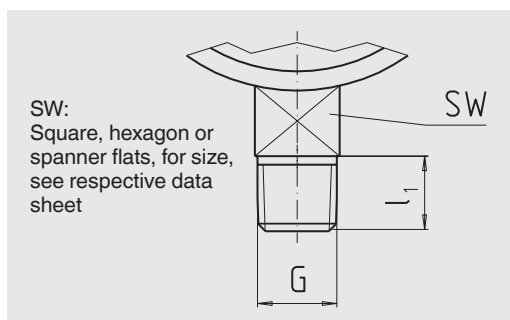

Tapered thread G	Dimensions in mm $l_1$ min.
1/8 NPT, R 1/8	10
1/4 NPT, R 1/4	13
3/8 NPT, R 3/8	15
1/2 NPT, R 1/2	19

## Tapped hole with parallel female thread

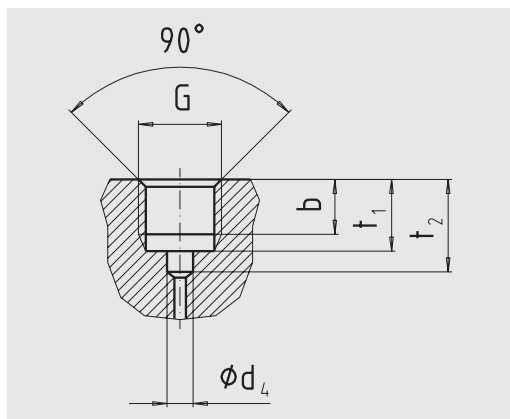

Parallel female thread G	Dimensions in mm			
	b min.	$d_4$	$t_1 -0.5$	$t_2$ min.
G 1/8 1)	7.5	4.4 3)	10	13
M10 x 1	7.5	4.5 3)	10	13
G 1/4 1)	10	5.5	13	16.5
M12 x 1.5	9.5	5.5	13	16.5
G 3/8	12	6.5	16	19.5
G 1/2 1)	15	7	19	24.5
M20 x 1.5	15.5	7	19	24.5

- 1) Preferably with WIKA standard versions  
3) Can be omitted with WIKA instruments since without centring spigot

## Standards for threads

Parallel threads: Pipe threads, code G, per ISO 228-1  
Metric ISO threads, code M, per DIN 13

Tapered threads: Pipe threads, code NPT, per ANSI / ASME B1.20.1  
Pipe threads, code R, per ISO 7

## Maximum allowable pressure

Thread 1)	Maximum allowable pressure 2)					
	Cu alloy		Stainless steel		Monel®	
	bar	psi	bar	psi	bar	psi
G 1/8	400	6,000	400	6,000	400	6,000
G 1/4	600	8,600	1,000	15,000	1,000	15,000
G 3/8	600	8,600	1,000	15,000	1,000	15,000
G 1/2	1,000	15,000	2,500	36,000	2,500	36,000
M10 x 1	400	6,000	400	6,000	400	6,000
M12 x 1.5	400	6,000	400	6,000	400	6,000
M20 x 1.5	1,000	15,000	2,500	36,000	2,500	36,000
1/8 NPT, R 1/8	400	6,000	400	6,000	400	6,000
1/4 NPT, R 1/4	600	8,600	1,000	15,000	1,000	15,000
3/8 NPT, R 3/8	600	8,600	1,000	15,000	1,000	15,000
1/2 NPT, R 1/2	1,000	15,000	1,600	23,000	1,600	23,000
7/16-20 UNF	400	6,000	800	12,000	800	12,000

1) Valid for the thread standards for connection shanks and female threads mentioned on page 2.

2) The specified values for the maximum pressure are rounded values and are assigned to the nearest standard scale range.

## Examples of industry-specific process connections

**Hydraulic connection  
with 74° sealing cone SAE J 514**

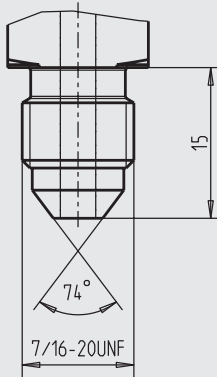

**Refrigeration connection  
with 90° sealing cone SAE J 513**

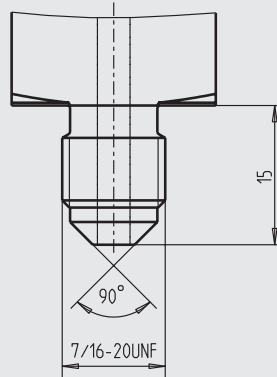

**High-pressure process connection  
per Autoclave Engineering or Nova  
Swiss M16 x 1.5 female**

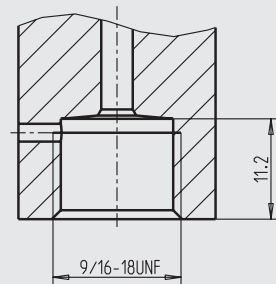

**High-pressure process connection  
(HP) for connection with lens-type  
sealing ring, per EN 837**

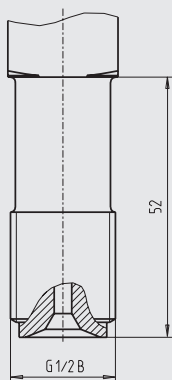

**Hose connection**

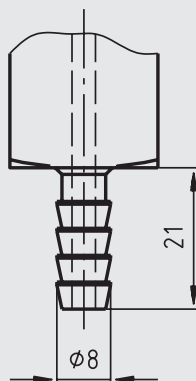

Other process connections on request

# Examples of other tapped holes

## Version per DIN EN ISO 1179-2 (sealing with profile sealing)

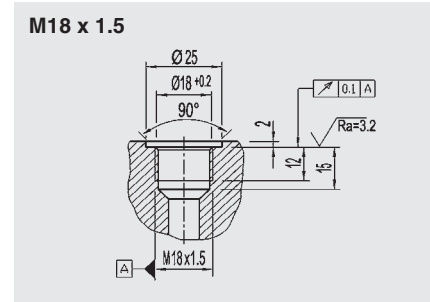
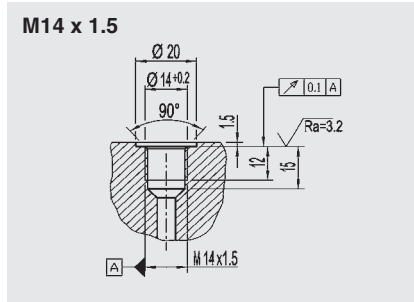
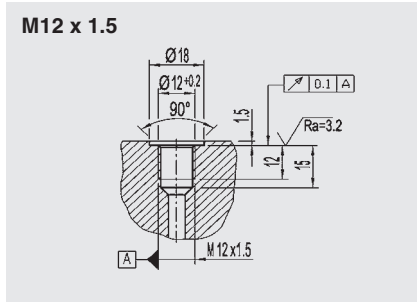
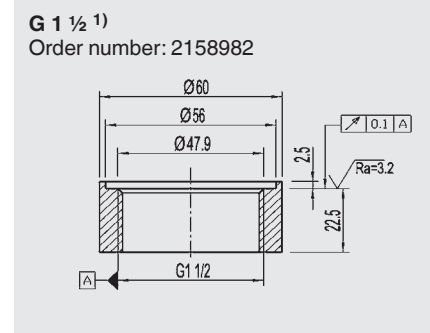
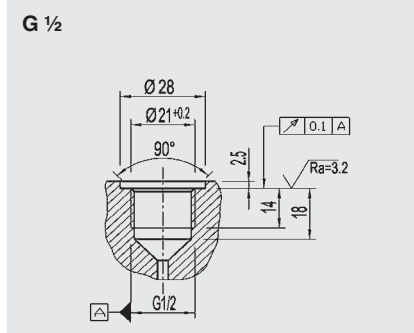
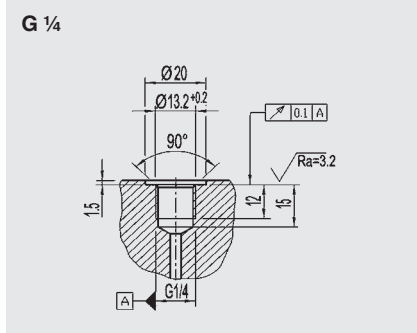

## Version per ANSI / ASME B1.20.1

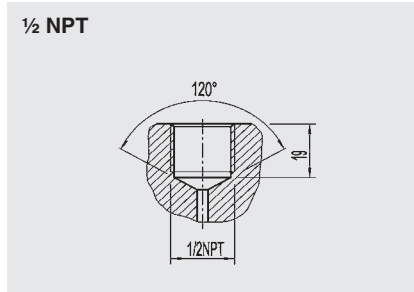
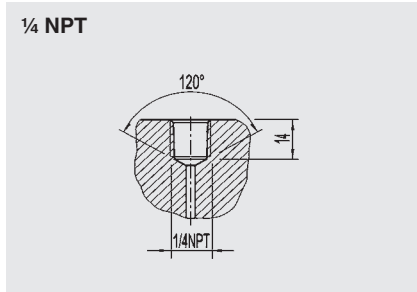

## Version per SAE J 514

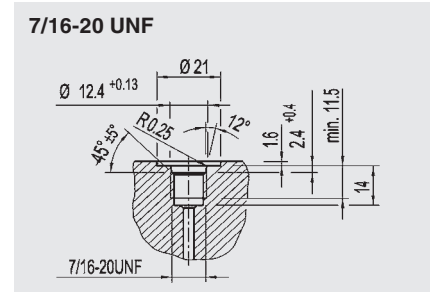

## Flush WIKA version

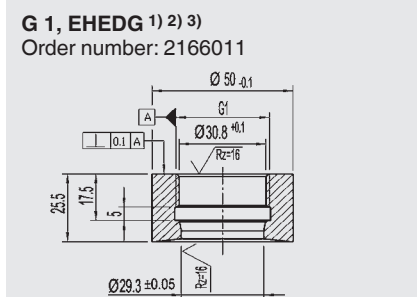
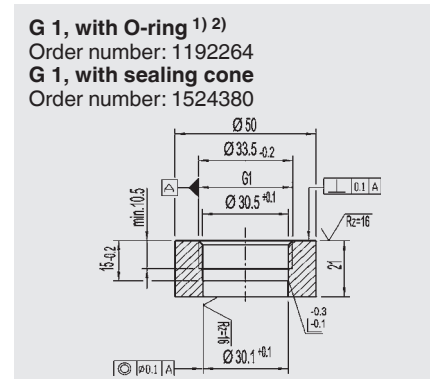
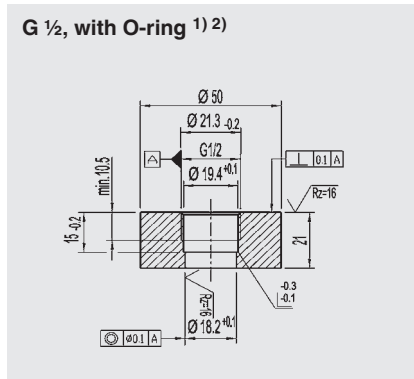
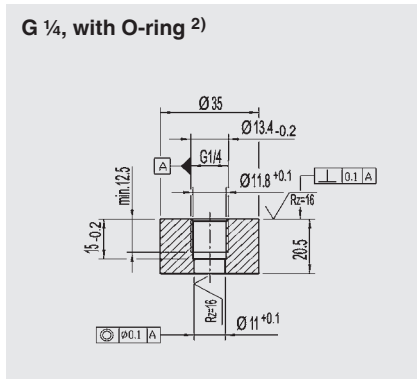

- 1) Also available as welding socket from WIKA.
- 2) The screw-in holes made by the customer must be drilled out after thread cutting.
- 3) European Hygienic Engineering & Design Group

WIKA makes every effort to ensure that the screw-in holes shown are kept up-to-date. The corresponding current regulations are applicable for the production of the screw-in hole. We reserve the right to make technical changes to the WIKA versions for screw-in holes and welding sockets.

© 09/2000 WIKA Alexander Wiegand SE & Co. KG, all rights reserved.  
The specifications given in this document represent the state of engineering at the time of publishing.  
We reserve the right to make modifications to the specifications and materials.



**WIKA Alexander Wiegand SE & Co. KG**  
Alexander-Wiegand-Straße 30  
63911 Klingenberg/Germany  
Tel. +49 9372 132-0  
info@wika.de  
www.wika.de